

# SG 2750

---

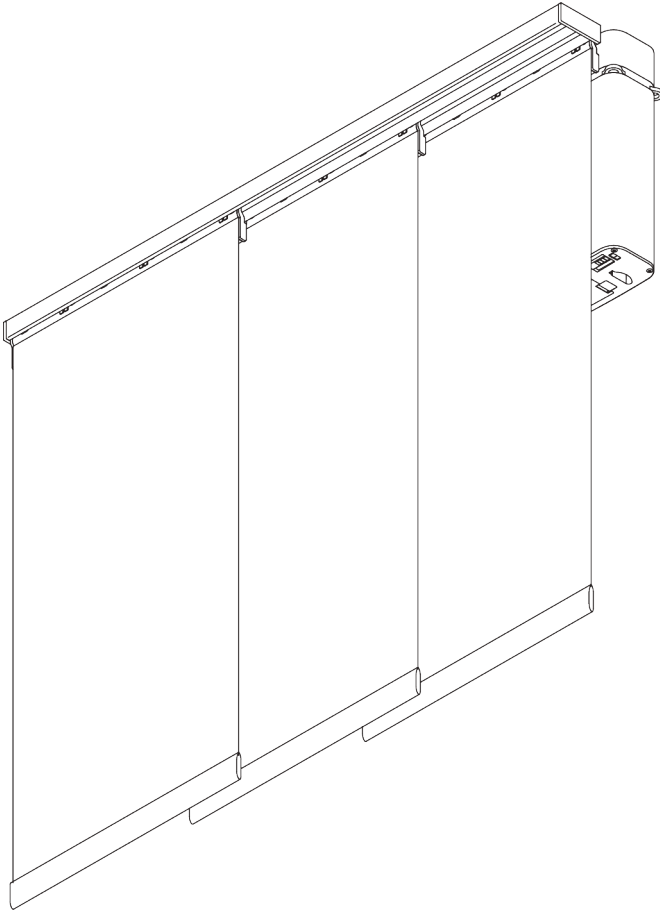
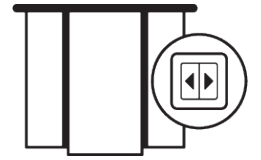

## PRODUCT INFORMATION

- **Operation:** motorised
- **Range:** S - L
- **Fitting:** ceiling
- **Colours:** white RAL 9016; special colours or anodised aluminum possible
- **Fabrics:** refer to Silent Gliss fabric collection

### **Features:**

- 2-component (2C) roller technology
- Silent and smooth running
- Aluminium carriers
- Applicable with electric curtain track system SG 5600

# SYSTEM SPECIFICATIONS

## A. SYSTEM DIMENSIONS

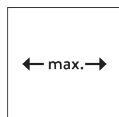

6 m

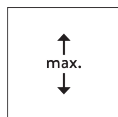

4 m



max. 2 kg per m

## B. PROFILE

### Profile information

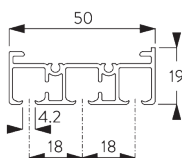

**SG 10123**

Profile 3-channel

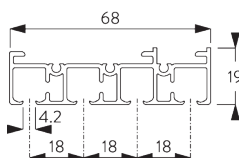

**SG 10124**

Profile 4-channel

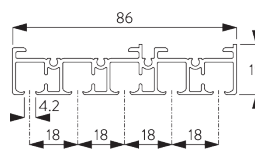

**SG 10125**

Profile 5-channel

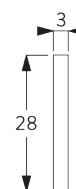

**SG 2006**

Bottom bar 28x3 mm

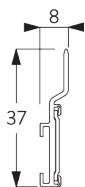

**SG 10230**

Carrier alu

## C. HOW TO MEASURE

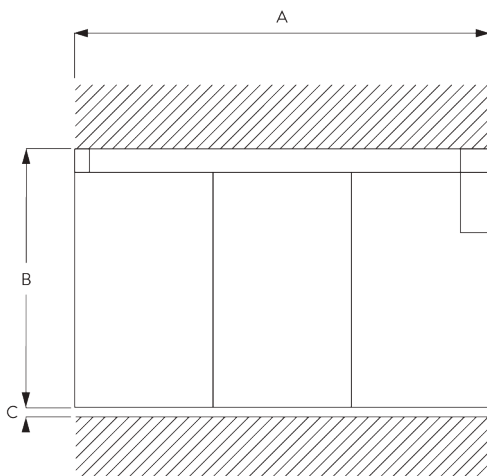

A: System width

B: System height

C: Distance between floor and fabric

## Dimensions of Panels

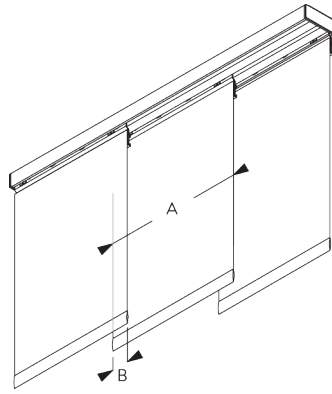

A: Recommended panel width: 500 - 1200

B: Overlap: min. 50

## D. SPECIFICATION

### TEXT

**Silent Gliss SG 2750 Electrically Operated Panel Glide System.** Supplied made to measure and complete comprising profiles SG 10123 / SG 10124 / SG 10125 as necessary with carriers SG 10230 with associated components and bottom weight SG 2006. Fabric panels stack right hand single / left hand single / pair / centre. Electrically operated (incorporating electric curtain track system SG 5600). Ceiling fixed using clamps SG 3003 / SG 3004. Fabric to be chosen from Silent Gliss fabric collection, Price Group 1 / 2 / 3 / 4.

# FITTING

## A. FITTING INFORMATION

For detailed fitting information, visit the Silent Gliss website.

### Fixing points

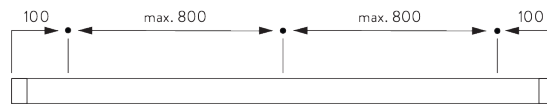

## B. CEILING FITTING

### With SG 5600

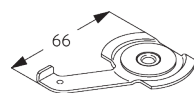
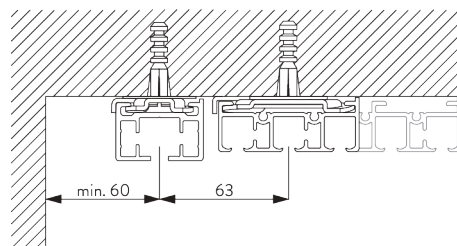

**SG 3003**  
Clamp

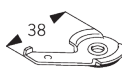

**SG 3004**  
Clamp

# SYSTEM OPTIONS

## A. MOTORISATION

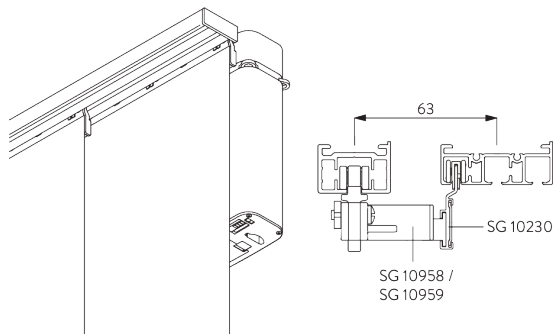

### Motorised with SG 5600

- Single stack systems: carrier SG 10958
- Pair stack systems: carriers SG 10958 / SG 10959

For further details refer to the electric curtain track catalogue.

## B. PANEL STACKING



Single stack

Note: dot = fixed panel









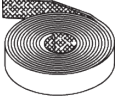
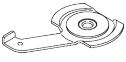

Pair stack

Note: dot = fixed panel

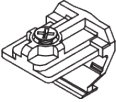
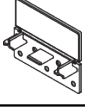
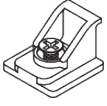
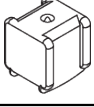
Other variations are possible.

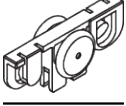

# PARTS

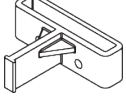
## A. STANDARD PARTS

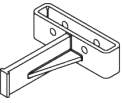
	<b>SG 2006</b> Bottom bar 28x3 mm
	<b>SG 2539</b> Tape
	<b>SG 3003</b> Clamp
	<b>SG 10123</b> Profile 3-channel
	<b>SG 10140</b> Angle
	<b>SG 10143</b> Cover
	<b>SG 10146</b> Angle
	<b>SG 10156</b> End stop
	<b>SG 10159</b> Countersunk head screw 3.5x13
	<b>SG 10200</b> 2C roller
	<b>SG 10230</b> Carrier alu
	<b>SG 10252</b> End cover left
	<b>SG 10253</b> End cover right
	<b>SG 10958</b> Panel carrier for electric track

	<b>SG 10959</b> Panel carrier for electric track
-----------------------------------------------------------------------------------	-----------------------------------------------------

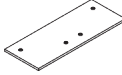
## B. OPTIONAL PARTS

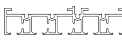
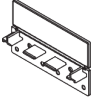
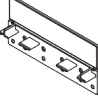
	<b>SG 2005</b> Bottom bar 40x5 mm
	<b>SG 6024</b> Connection bridge
	<b>SG 10124</b> Profile 4-channel
	<b>SG 10125</b> Profile 5-channel
	<b>SG 10144</b> End cover
	<b>SG 10145</b> End cover

[www.bradingfabrication.com](http://www.bradingfabrication.com)

Brading Fabrication Limited  
1885 Clements Road, Unit 228  
Pickering, ON, Canada  
L1W 3V4

Tel: 1-800-483-5550

[info@bradingfabrication.com](mailto:info@bradingfabrication.com)