

SG 6243

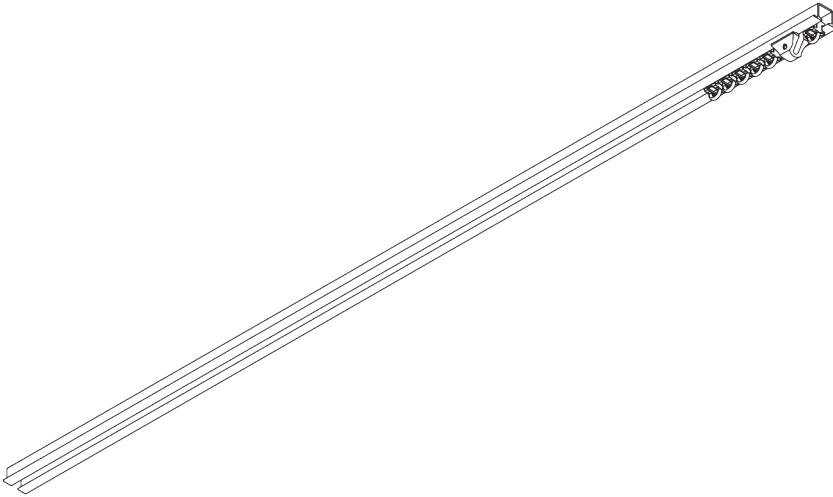

PRODUCT INFORMATION

- **Operation:** hand
- **Range:** S - M
- **Fitting:** recess
- **Colours:** white RAL 9016; special colours or anodised aluminum possible
- **Fabrics:** refer to Silent Gliss fabric collection

Features:

- 2-component (2C) glider technology
- Wave (2C)
- Bendable
- Pre-drilled profile

SYSTEM SPECIFICATIONS

A. PROFILE

Profile and bending information

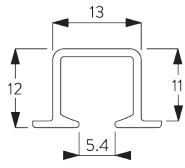

SG 6243p

Profile

Radius:
20 cm, >25 cm

B. HOW TO MEASURE

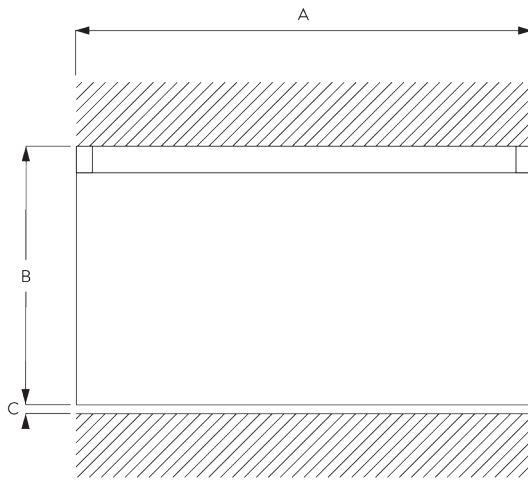

A: System width
B: System height
C: Distance between floor and fabric

C. SPECIFICATION TEXT

Silent Gliss SG 6243 Hand Operated Curtain Track System. Comprises aluminium profile SG 6243 supplied made to measure powder coated white with gliders SG 11300 at 14/m, 1 end stop SG 6065 and 1 spring stop SG 6053 per length. Top fixed with screw SG 0240 into timber through pre drilled holes every 200mm.

FITTING

A. FITTING INFORMATION

Fixing points

For detailed fitting information, visit the [Silent Gliss website](#).

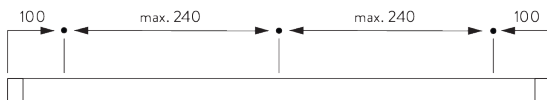

B. RECESS FITTING

Direct into wood

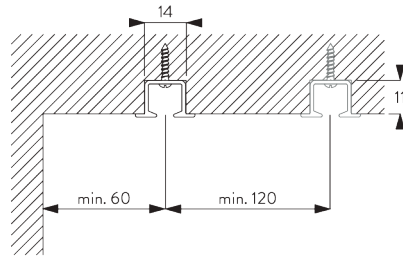

Recess channel: 11 x 14 mm

SYSTEM OPTIONS

A. WAVE

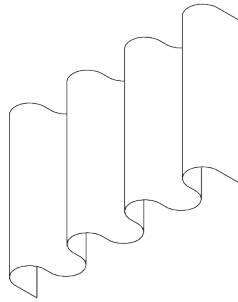

SG 11295

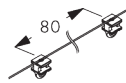

SG 11302

Standard components:

- SG 11295 End stop
- SG 11302 Wave 2C glider cord 80 mm



SG 2255



SG 2256

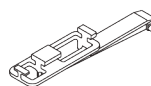

SG 6364



SG 6365

Optional components (min. radius >25 cm):

- SG 2255 Brake
- SG 2256 Brake
- SG 6364 Wave extension
- SG 6365 Wave hanger
- SG 6366 Wave carrier for draw rod
- SG 10430-34 Draw rod
- SG 11303 Wave 2C glider cord 60 mm

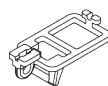

SG 6366



SG 10430-34

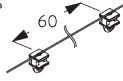

SG 11303

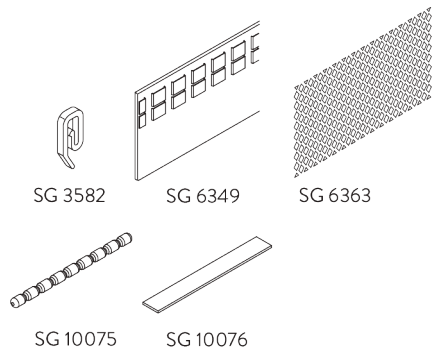

Curtain components:

- SG 3582 Hook
- SG 6349 Wave curtain tape
- SG 6363 Wave top hemming tape
- SG 10075 Lead weight 50 gr/m
- SG 10076 Fabric weight

Wave stack depth - 2C glider cord (standard components)

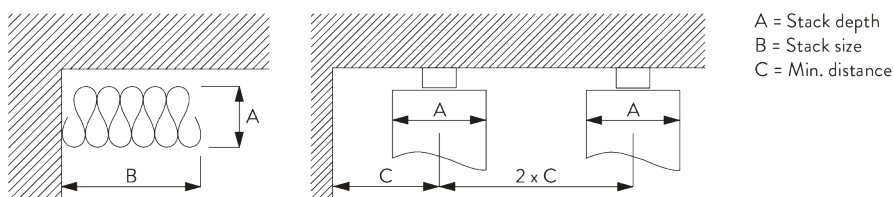

A = Stack depth
 B = Stack size
 C = Min. distance





2C Glider cord SG 11302	Pockets between hooks	Approx. curtain fullness	Stack depth A	Stack size B*	Min distance C
80	6	~2.1	140	180 per metre of track	90
80	7	~2.3	160	180 per metre of track	100

2C Glider cord SG 11303	Pockets between hooks	Approx. curtain fullness	Stack depth A	Stack size B*	Min distance C
60	4	~2.1	100	230 per metre of track	70
60	5	~2.3	120	230 per metre of track	80





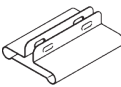

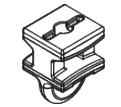

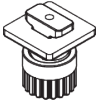
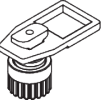
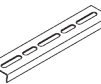

*Stack size B when using optional extension arm SG 6364 increases by 95 mm per curtain!





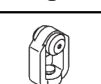



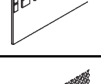

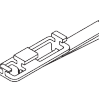
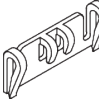

PARTS

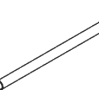
A. STANDARD PARTS

	SG 6053 Spring stop
	SG 6065 End stop
	SG 6243p Profile
	SG 7002 Profile protector
	SG 10717 Countersunk head screw 2.2x19
	SG 11300 2C glider

B. OPTIONAL PARTS

	SG 2255 Brake
	SG 2256 Brake
	SG 3067 Connection bridge
	SG 3562 Heading tape
	SG 3571 Hook
	SG 3582 Hook
	SG 3599 Hook
	SG 6064 End stop
	SG 6094 Roller
	SG 6098 Roller
	SG 6099 Wave roller cord 80 mm
	SG 6283 Roller
	SG 6349 Wave curtain tape
	SG 6363 Wave top hemming tape

	SG 6364 Wave extension
	SG 6365 Wave hanger
	SG 6366 Wave carrier for draw rod
	SG 10075 Lead weight 50 g/m
	SG 10076 Fabric weight
	SG 10430 Draw rod 50 cm
	SG 10431 Draw rod 75 cm
	SG 10432 Draw rod 100 cm
	SG 10433 Draw rod 125 cm
	SG 10434 Draw rod 150 cm
	SG 11295 End stop
	SG 11301 2C glider on strip
	SG 11302 Wave 2C glider cord 80 mm
	SG 11303 Wave 2C glider cord 60 mm

www.bradingsfabrication.com

Brading Fabrication Limited
1885 Clements Road, Unit 228
Pickering, ON, Canada
L1W 3V4

Tel: 1-800-483-5550

info@bradingsfabrication.com