



Enhance your Solarium Experience

Enhance the beauty, functionality, comfort and value of your Solarium with the SolaraShade™ Shading System by Brading. SolaraShade™ is designed to maximize the benefits of your Solarium, Conservatory, or Patio Room. This specially designed shading system will:

- Add comfort by moderating temperature fluctuations
- Control glare for better reading, computer use or watching TV
- Allow you to enjoy natural light while maintaining full privacy
- Help protect your furniture and fabrics from fading
- Match your decor and add style to your solarium experience
- Save you money on energy costs

SolaraShade™ is a high quality, high performance shading system designed and manufactured by Brading Fabrication. Our strategy has always been to provide customers with shading systems that will last for many years. That is why SolaraShade™ fabrics and hardware are engineered to withstand seasonal temperature fluctuations as well as damaging ultraviolet light.

PROVEN DESIGN FOR LONG LASTING VALUE

SolaraShade™ is a proven shading system that integrates a durable, long lasting blind fabric with a smooth flowing tracking system to provide you with unmatched quality and enduring value. SolaraShade™ 100% non-woven polyester fabric is spun to create a high quality textile which offers long term durability. The fabric's uniform white backing provides reflection of radiant heat while maximizing light penetration and presents a clean uniform exterior appearance.

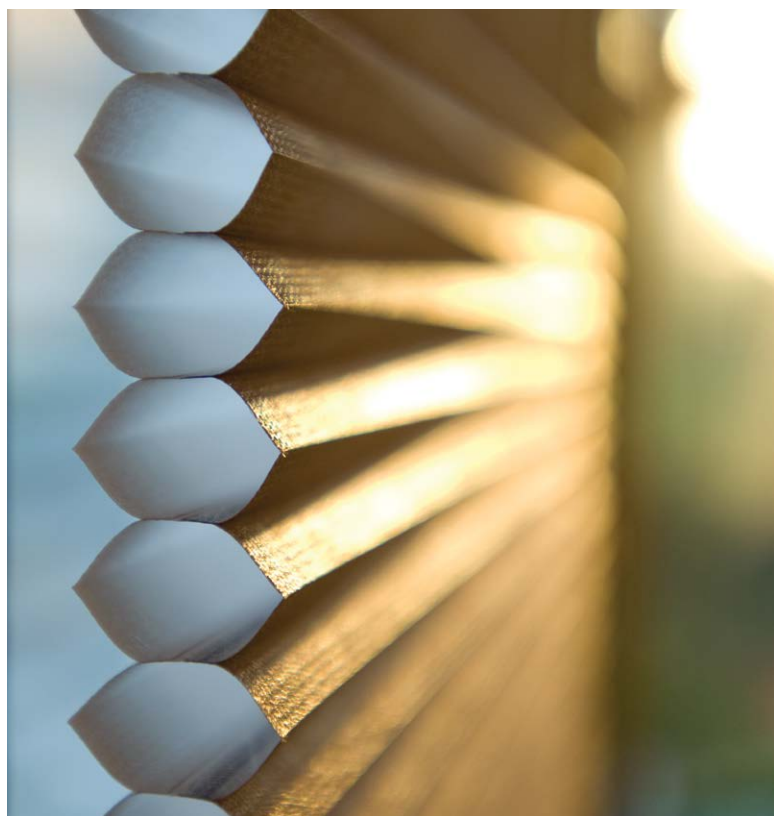



The unique SolaraShade™ tracking system is designed to work harmoniously with the honeycomb fabric for years of flawless operation and is backed by a five year warranty. The use of UV and heat resistant polycarbonate plastic or colored aluminum tracking materials. The plastic tracks in particular are supplied “optically clear” and virtually disappear upon installation. SolaraShade™ blinds are notched at the ends to invisibly guide the blinds in a smooth flowing manner. Our design allows the shades to conform perfectly to the curvature of the solarium while providing a leak resistant “thermal air blanket” to greatly reduce energy costs.

All SolaraShade™ fabrics easy to maintain. They can be cleaned by dusting or gentle vacuuming and washed with damp sponge with mild soap solution.

SMOOTH FLOWING TRACKING HARDWARE

Engineered for long term use, the innovative gear driven tracking system keeps blind fabric securely in place while creating a “thermal air blanket” to save energy costs. Our “optically clear” polycarbonate plastic tracking system option is virtually invisible when the blinds are retracted.

ENERGY EFFICIENT HONEYCOMB FABRIC

The fabric’s honeycomb design and uniform white backing provide exceptional thermal insulating properties, while maximizing light penetration and providing a clean uniform exterior appearance. Available in the slim 3/8” or the larger 3/4” formats, these blinds virtually disappear when not in use by compressing to about 5% of their expanded size.

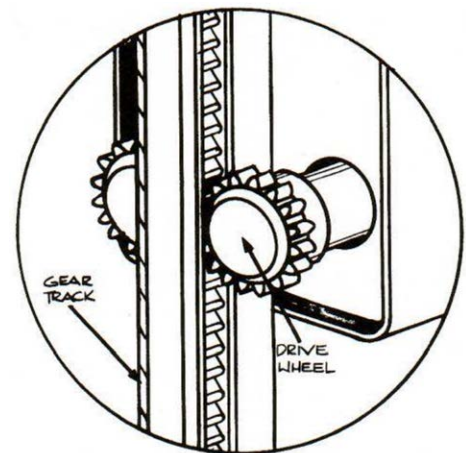

DRIVE WHEEL DETAIL

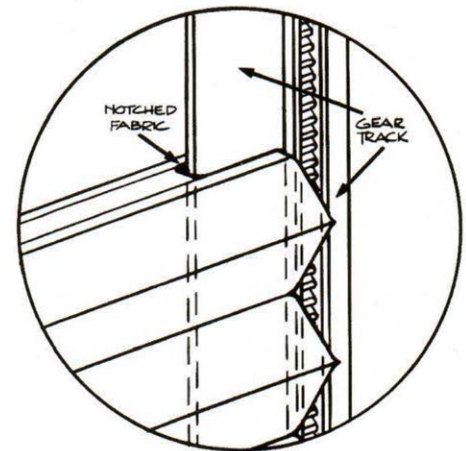

NOTCHED FABRIC DETAIL